

Description

The SR70L is a low capacitance TVS diode array, utilizing leading monolithic silicon technology to provide fast response time and low ESD clamping voltage, making this device an ideal solution for protecting sensitive semiconductor components from damage. The SR70L complies with the IEC 61000-4-2 (ESD) with $\pm 15\text{kV}$ air and $\pm 8\text{kV}$ contact discharge. It is assembled into a lead-free SOT-143 package. It is designed to protect components which are connected to high speed interfaces and transmission lines from voltage surges.

Features

- ◆ 350W peak pulse power(8/20 μs)
- ◆ Operating voltage: 70V
- ◆ Low capacitance for high-speed data line
- ◆ Low clamping voltage
- ◆ Complies with following standards:
 - IEC 61000-4-2 (ESD) immunity test
 - Air discharge: $\pm 15\text{kV}$
 - Contact discharge: $\pm 8\text{kV}$
 - IEC61000-4-5 (Lightning) 21A (8/20 μs)
- ◆ RoHS Compliant

Mechanical Characteristics

- ◆ Package: SOT-143
- ◆ Lead Finish: Matte Tin
- ◆ Case Material: “Green” Molding Compound.
- ◆ Moisture Sensitivity: Level 3 per J-STD-020
- ◆ Terminal Connections: See Diagram Below
- ◆ Marking Information: See Below

Applications

- ◆ ADSL Lines
- ◆ Video Line Protection
- ◆ I2C Bus Protection
- ◆ LAN/WAN equipment
- ◆ Portable Electronics
- ◆ ISDN S/T Interface

Dimensions and Pin Configuration

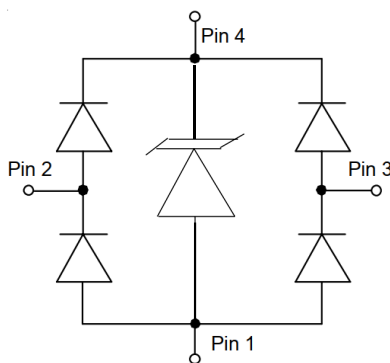

Circuit Diagram

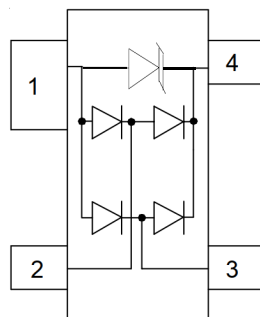

Pin Schematic

Marking Information

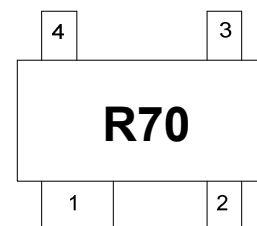

R70= Device Marking Code

Ordering Information

Part Number	Marking	Packaging	Reel Size
SR70L	R70	3000/Tape & Reel	7 inch

Absolute Maximum Ratings ($T_A=25^\circ\text{C}$ unless otherwise specified)

Parameter	Symbol	Value	Unit
Peak Pulse Current (8/20 μs)	I _{PP}	21	A
Rectifier Repetitive Peak Reverse Voltage	V _{RRM}	70	V
ESD per IEC 61000-4-2 (Air)	V _{ESD}	± 15	kV
ESD per IEC 61000-4-2 (Contact)		± 8	
Operating Temperature Range	T _J	-55 to +125	°C
Storage Temperature Range	T _{stg}	-55 to +150	°C

Electrical Characteristics ($T_A=25^\circ\text{C}$ unless otherwise specified)

Parameter	Symbol	Min	Typ	Max	Unit	Test Condition
Reverse Working Voltage	V _{RWM}			70	V	
Punch-Through Voltage	V _{BR}	85			V	I _T = 50 μA
Reverse Leakage Current	I _R			0.5	μA	V _{RWM} = 70V
Clamping Voltage	V _C			3.0	V	I _{PP} = 1A (8 x 20 μs pulse)
Clamping Voltage	V _C			10.0	V	I _{PP} = 10A (8 x 20 μs pulse)
Clamping Voltage	V _C			16.0	V	I _{PP} = 21A (8 x 20 μs pulse)
Junction Capacitance	C _J		2.0	3.0	pF	V _R =0, f=1MHz, between I/O pins and Ground
Junction Capacitance	C _J		1.0		pF	V _R =0, f=1MHz, between I/O pins

Typical Performance Characteristics (TA=25°C unless otherwise Specified)

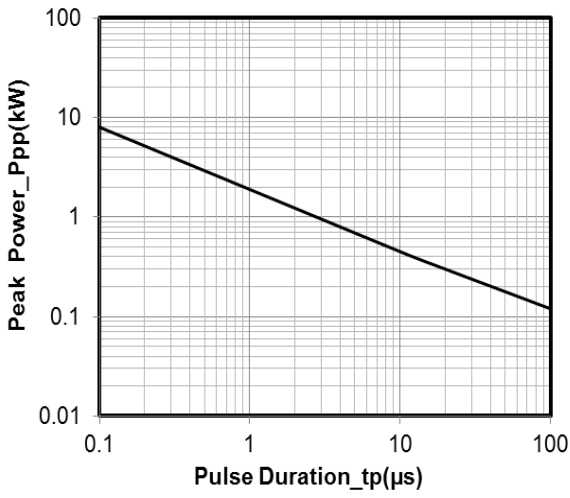

Peak Pulse Power vs. Pulse Time

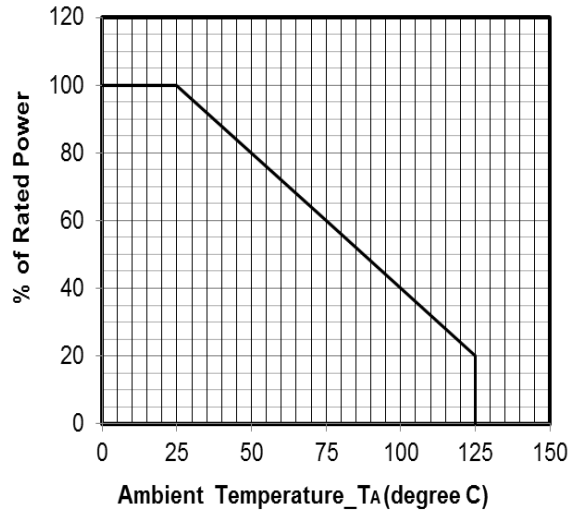

Power Derating Curve

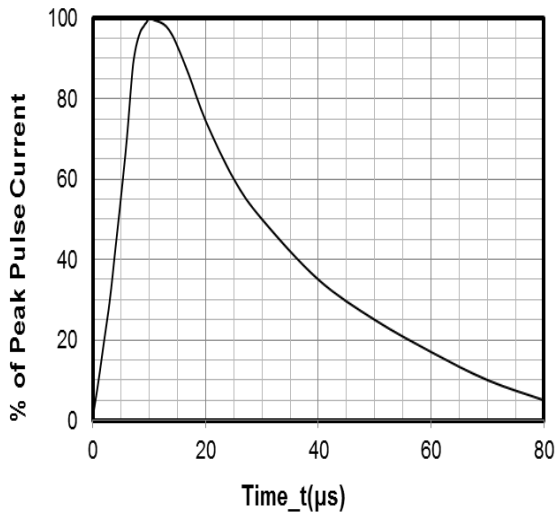

8 X 20μs Pulse Waveform

SOT-143 Package Outline Drawing

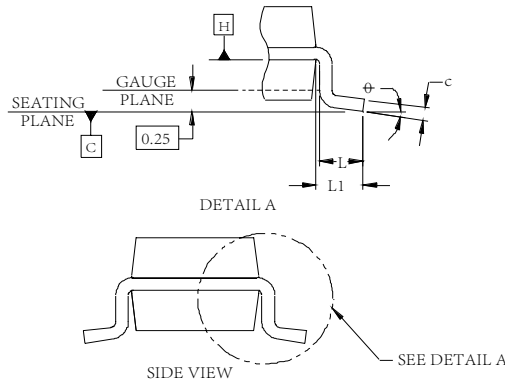
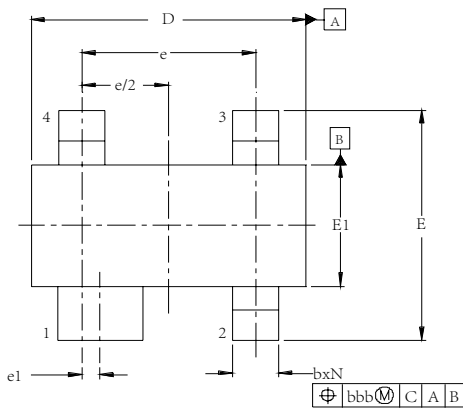

DIM	DIMENSIONS					
	INCHES			MILLIMETERS		
	MIN	NOM	MAX	MIN	NOM	MAX
A	.031	-	.048	0.80	-	1.22
A1	.000	-	.006	0.013	-	0.15
A2	.029	.035	.042	0.75	0.90	1.07
b	.011	-	.020	0.30	-	0.51
b1	.029	-	.037	0.76	-	0.94
c	.003	-	.008	0.08	-	0.20
D	.110	.114	.120	2.80	2.90	3.04
E	.082	.093	.104	2.10	2.37	2.64
E1	.047	.051	.055	1.20	1.30	1.40
e	.075			1.92 BSC		
e1	.008			0.20 BSC		
L	.015	.020	.024	0.40	0.50	0.60
L1	(0.021)			(0.54)		
N	4			4		
phi	0°	-	8°	0°	-	8°
aaa	.006			0.15		
bb b	.008			0.20		
ccc	.004			0.10		

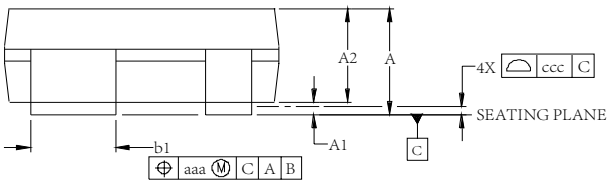

Suggested Land Pattern

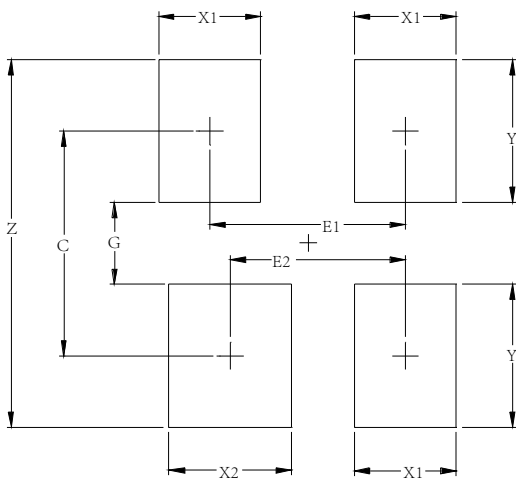

SYM	DIMENSIONS	
	MILLIMETERS	INCHES
C	2.20	0.087
E1	1.92	0.076
E2	1.72	0.068
G	0.80	0.031
X1	1.00	0.039
X2	1.20	0.047
Y	1.40	0.055
Z	3.60	0.141

Contact Information

Changzhou D-first Electronics CO.,Ltd.
 www.first-electronic.com
 Email: xhf@first-electronic.cn
 Phone: +86 (0519) 8817 1671